

8 7 6 5 4 3 2 1

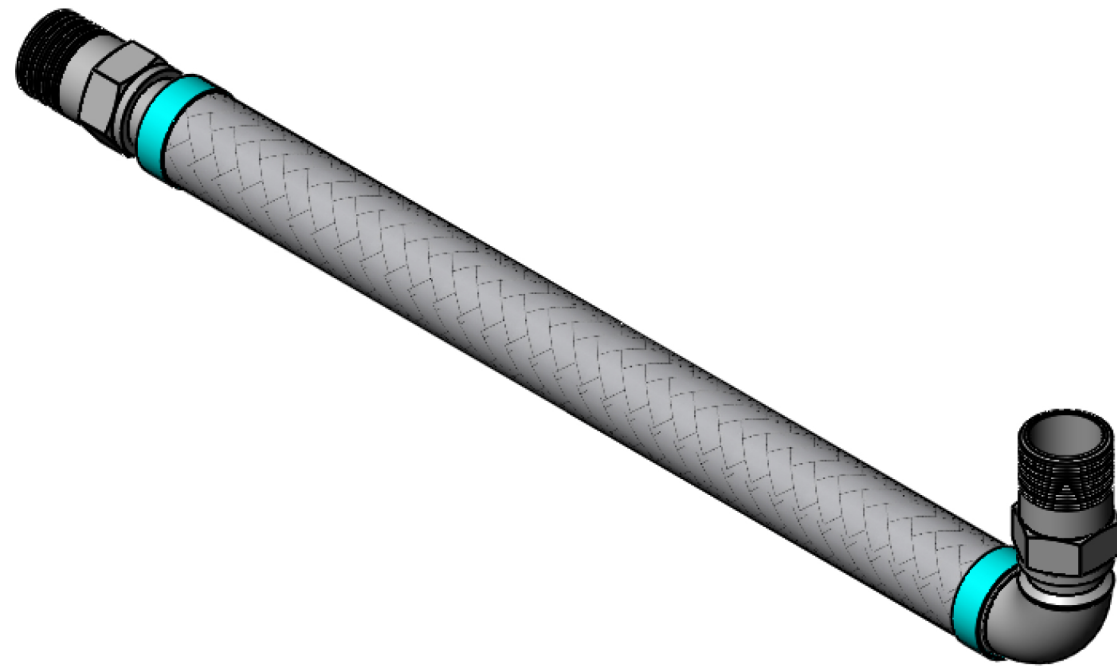
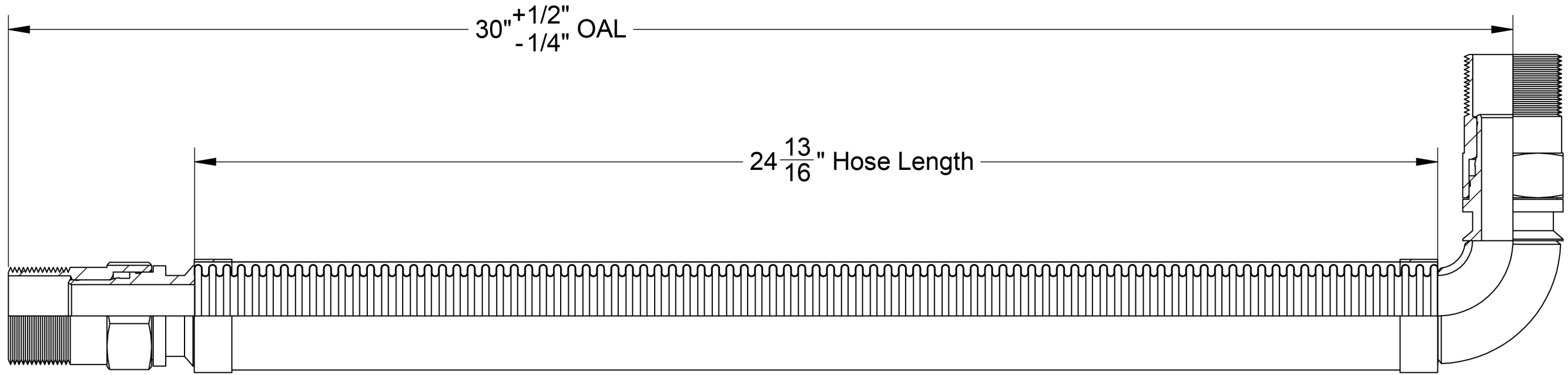

ITEM #	QTY.	PART NUMBER	DESCRIPTION	MATERIAL	WEIGHT
1	1	HOSE	300 Series Stainless HYDROFORMED Corrugated Hose	Stainless Steel	1.06
2	1	BRAID	300 Series Stainless Steel	Stainless Steel	0.10
3	2	BRAID COLLAR	0.05" Thick	Stainless Steel	0.07
4	2	1.5" MALE SWIVEL	1.5" Male Swivel, 1-1/2"x11-1/2" Thread, 1.94" Hex	Carbon Steel	1.40
5	1	1.5" ELBOW	1.5" Short Radius Elbow, Sch. 40	Carbon Steel	0.52

		HOSE MASTER Inc. 1233 East 222nd Street • Cleveland, Ohio 44117 (800) 221-2319 • Fax: (216) 481-7557 • www.hosemaster.com Locations: Cleveland • Houston		Registered to: ISO 9001 : 2000
		Projection:	Customer: Hose Master Inc.	Prepared By: kannk
Description: 1.5" ID x 30" OAL 300 Series Stainless HYDROFORMED Corrugated Hose covered by 300 Series Stainless Braid. UL Approved 1.5" Male Swivel Connector x 1.5" ID 90 Degree Male Swivel Connector				
Drawing #: FSSSE0150x30			Rev.: -	SHEET 1 OF 1

REVISIONS			
REV.	DESCRIPTION	DATE	APPROVED
8		7	6

8 7 6 5 4 3 2 1